



150W BabyLED

Type 8921 Tungsten

Type 8931 Daylite

It looks like a Baby. It feels like a Baby. And most importantly, it performs like a Baby. Seamless integration with existing Tungsten Halogen Incandescent, similar performance and optics as other 6" (152mm) Mole Fresnels, and about 80% less power consumption.



Specifications

Heads: Type 8921 Tungsten and Type 8931 Daylite

Rating: 90-250 Volts AC, 50-60Hz, 150 Watts, 0.75-1.5 Amps Max.
DMX Standby Draw <.08 Amps Max.

Light Source: (1) - 150 Watt Mole-Richardson Quantum Dot LED
3200K 95CRI Tungsten & 5600K 90CRI Daylight

Cable: Attached 25 ft (7.6m) Type SO., 3 Conductor,
#18 AWG with NEMA 5-15 Edison
(Other plugs and wire lengths available upon request)

Switch: Thru-cord Toggle in Cable, DMX or Local Toggle in Trough

Fuse: 1.5 Amp Slow-Blow. Fuseholder in Trough

Dimming: Flicker Free, Direct DC Dimming
On-Board Dimmer 100% -10% (Minimal Color Shift)
DMX Dimmer 100% - 0% (Minimal Color Shift)

Control: DMX512-A In and Out. Manual DMX Address Selector

Condenser: 6 in (152mm) Borosilicate Glass Fresnel

Beam Angle: 10° to 55° Variable Spot to Flood (Includes Field)

Focusing: Rotating Knob on Front and Back

Cooling: Passive-Forced Air

Construction: Aluminum and Steel with Interlocking Channels

Yoke: Cast Aluminum w/Standard 5/8 in (16mm) Receiver

Compliance: RoHS, CE, UL, CSA Pending

IP Rating: 30

Finish: Textured Black Powder Epoxy Coat. (Other Colors Available)

Size: 11 in/279mm(d) x 11 in/279mm(w) x 17¹/₄ in/438mm(h)

Head Weight: 8.5lbs/3.86kg (Head Only)
11lbs/4.99kg (Head with 25ft/7.6m cable)

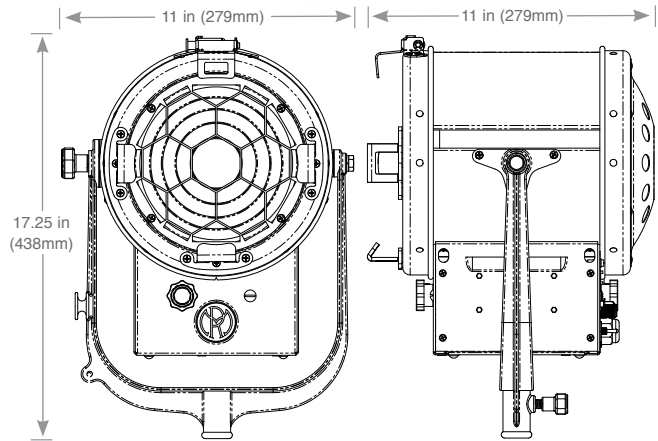

Accessories

Item Number

2-Way Barn Door (2 Leaf)	40755
4-Way BabyLED Barn Door (4 Leaf)	89285
4-Way Barn Door (8 Leaf)	407156
Moledisc Diffuser Frame (6 ⁵ / ₈ in/168mm)	40748A
Snoot (Set of 3)	40747A
Molesnoot (Five-in-one)	407184
Apertures: 2 in, 2 ³ / ₈ in, 2 ¹ / ₄ in, 3 ¹ / ₈ in and 3 ¹ / ₂ in (50mm, 60mm, 70mm, 79mm and 89mm)	
Half Single Scrim—Stainless Steel (6 ⁵ / ₈ in/168mm)	407281S
Half Double Scrim—Stainless Steel (6 ⁵ / ₈ in/168mm)	407281D
Single Scrim—Stainless Steel (6 ⁵ / ₈ in/168mm)	407280S
Double Scrim—Stainless Steel (6 ⁵ / ₈ in/168mm)	407280D
Scrim Bag	G136
150 Watt BabyLED Retrofit Kit, Tungsten	892110
150 Watt BabyLED Retrofit Kit, Daylite	893110

Performance Data

Using (1) 150 Watt Mole-Richardson QD LED.

Distance Feet (Meters)	Light Intensity Maximum Flood Foot Candles (Lux) Daylite	Light Intensity Maximum Flood Foot Candles (Lux) Tungsten	Light Intensity Maximum Spot Foot Candles (Lux) Daylite	Light Intensity Maximum Spot Foot Candles (Lux) Tungsten	Beam Diameter Maximum Flood Feet (Meters)	Beam Diameter Maximum Spot Feet (Meters)
5 (1.5)	460 (4,951)	370 (3,983)	1,800 (19,375)	1,300 (13,993)	3.5 (1.1)	0.9 (0.3)
10 (3.0)	130 (1,399)	100 (1,076)	380 (4,090)	370 (3,983)	7.0 (2.1)	1.7 (0.5)
15 (4.6)	60 (646)	55 (592)	260 (2,799)	170 (1,830)	10.5 (3.2)	2.6 (0.8)

Light tapers smoothly at edge of field. Dimensions listed define flat area boundaries at which the intensities are approximately 50% of tabulated intensities at beam center.

Mole-Richardson Co.

Mole-Richardson Co., 937 North Sycamore Avenue, Hollywood, California 90038 U.S.A.
Tel. +1-323-851-0111 • Fax. +1-323-851-5593 • E-Mail: info@mole.com • Web: http://www.mole.com
© 2013 Mole-Richardson Co., Hollywood, CA

MoleTM LED Fresnel

If there is one product synonymous with Mole-Richardson Co., it's the iconic Motion Picture Fresnel. Built in Hollywood California since 1936, the studio Fresnel remains the back-bone of professional lighting for the film, television and broadcast industries. Relatively unchanged since its origin, the studio Fresnel rarely saw dramatic improvements...until now.

Introducing the MoleLED Fresnels. A design familiar to generations of lighting professionals is now loaded with state

of the art electronics and the latest LED technology. These revolutionary fixtures use a proprietary Quantum Dot LED developed and produced by Mole to replicate film and television 3200K Tungsten and 5600K Daylight exactly.

High-output, with unparalleled color quality and a borosilicate glass Fresnel lens, the MoleLED Fresnels perform identically to an incandescent or HMI Fresnel fixture. In addition, Mole added features like a universal power supply, built-in local dimming as well as on-board DMX dimming. Now, you are no longer tied to an external dimming system or any one voltage.

In an industry inundated with mass produced, eco-friendly products, the MoleLED Fresnels are truly a hybrid of hand crafted quality and the most advanced solid state lighting technology available. From the ground up,



the MoleLED Fresnels are designed, engineered and built in the USA for professionals everywhere.

Product Benefits

- An 80% reduction in energy consumption
- Flicker-Free dimming with little to no color shift.
- No need for external dimming systems.
- No direct IR or radiant heat from Fresnel.
- And so much more...

Retro-Fit Kits

Realizing a need for our industry to further reduce, reuse and recycle, Mole is also offering simple retro-fit kits to convert existing legacy Tweenie, Baby and 8" Junior Solarspots to new Tungsten or Daylight MoleLEDTM Fresnels.

Control Panel

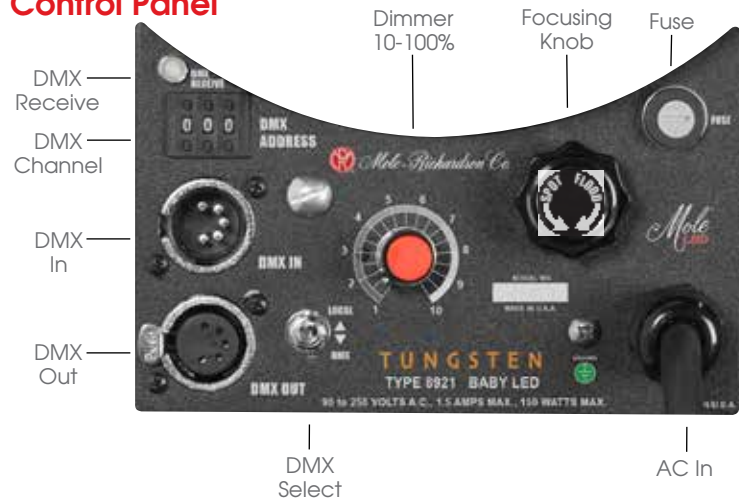

The Technology



The MoleLED Fresnels are powered by a new, proprietary Mole-Richardson Co. Quantum Dot chip on-board LED module. The benefit of QD LED technology is the ability to specifically tune the visible wavelength at the nano scale which, in this case, allows for precise adjustment of the red spectrum without impacting the overall light output of the LED. This Patent Pending LED board represents the first time QD LED's are being used in the film, television and broadcast industries.

